

# 8" E

## VACUUM-PRIME UNIT S 8" E/ J8-300 TWGMC/N75



### Features

- Automatic dry priming with vacuum pump
- Robust construction with cast iron separator
- Oil-lubricated vacuum pump with oil recovery system
- Self-priming water pump
- Heavy duty two-wheeled site trailer with lifting hook and articulated tow bar

### Performance

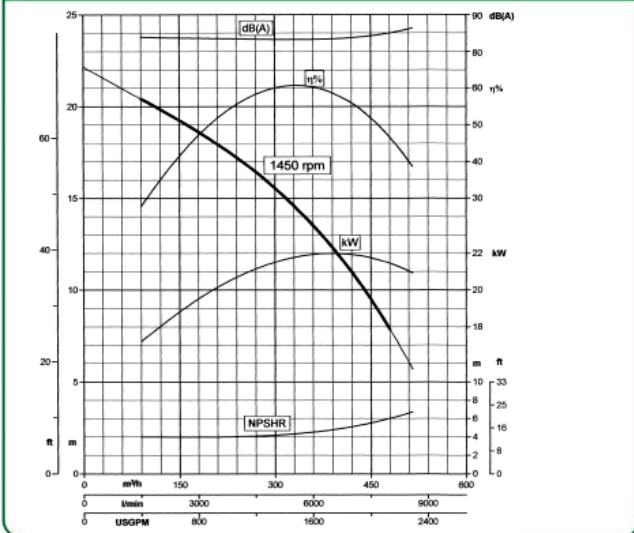

### Specifications

- Max. water capacity: 480 m<sup>3</sup>/h
- Max. head.: 22 m
- Speed: 1450 RPM
- Size of solids handled: 60 mm (4 blade impeller)
- Cast iron construction
- Rubber faced wear plate
- Silicon carbide mechanical seal with automatic lubricator
- Rated vacuum pump capacity: 75 m<sup>3</sup>/h
- Pump electric motor: 22 kW
- Control panel to CE standards

### Overall dimensions - Weight

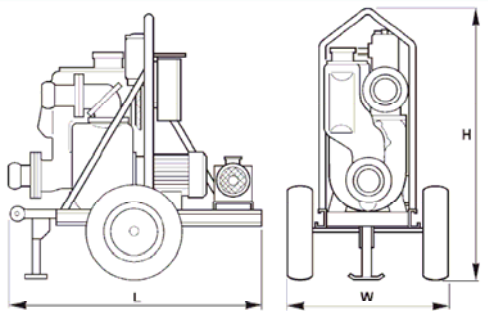

| L      | W      | H      | Weight |
|--------|--------|--------|--------|
| 2000mm | 1370mm | 1700mm | 850kg  |

### Applications

- Wellpoint dewatering systems
- Horizontal drainage with drainage hoses
- Construction site dewatering
- Sewage by-pass
- Quarries
- Sludge and slurry

Code: 10023570

List price:



**VARISCO S.p.A.**  
Zona Industriale Nord - 35129 PADOVA - ITALIA  
Direzione e Uffici: Terza Strada, 9 / Produzione e magazzini: Prima Strada, 37  
Tel. +39 049 8294111 - international +39 049 8294111  
Fax +39 049 8294373 +39 049 8076762  
italia@variscospa.com export@variscospa.com  
www.variscospa.com

AZIENDA CON SISTEMA  
GESTIONE QUALITA'  
CERTIFICATO  
UNI EN ISO 9001-2000