

4"E

VACUUM-PRIME UNIT S 4"E/ J4-250W TWGMC/N45



Features

- Automatic dry priming with vacuum pump
- Robust construction with cast iron separator
- Oil-lubricated vacuum pump with oil recovery system
- Self-priming water pump
- Heavy duty two-wheeled site trailer with lifting hook and articulated tow bar

Performance

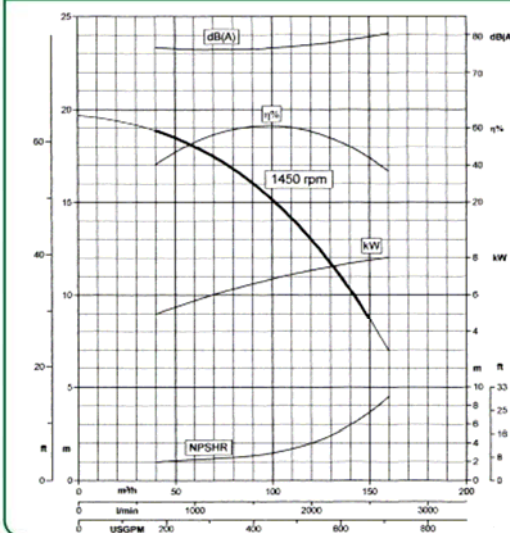

Specifications

- Max. water capacity: 150 m³/h
- Max. head.: 20 m
- Speed: 1450 RPM
- Size of solids handled: 45 mm (3 blade impeller)
- Cast iron construction
- Rubber faced wear plates
- Silicon carbide mechanical seal with automatic lubricator
- Rated vacuum pump capacity: 45 m³/h
- Pump electric motor: 7.5 kW
- Control panel to CE standards

Overall dimensions - Weight

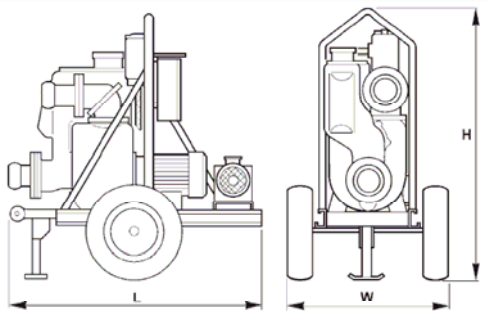

L	W	H	Weight
1740mm	960mm	1600mm	440kg

Applications

- Wellpoint dewatering systems
- Horizontal drainage with drainage hoses
- Construction site dewatering
- Sewage by-pass
- Quarries
- Sludge and slurry

Code: 10024220

List price:

varisco
a solid name in fluids

VARISCO S.p.A.
Zona Industriale Nord - 35129 PADOVA - ITALIA
Direzione e Uffici: Terza Strada, 9 / Produzione e magazzini: Prima Strada, 37
Tel. +39 049 8294111 - international +39 049 8294111
Fax +39 049 8294373 +39 049 8076762
italia@variscospa.com export@variscospa.com
www.variscospa.com

AZIENDA CON SISTEMA
GESTIONE QUALITA'
CERTIFICATO
UNI EN ISO 9001-2000