

# 10" E

## VACUUM-PRIME UNIT S 10" E/ J10-305 TWGMC/N75



### Features

- Automatic dry priming with vacuum pump
- Robust construction with cast iron separator
- Oil-lubricated vacuum pump with oil recovery system
- Self-priming water pump
- Heavy duty two-wheeled site trailer with lifting hook and articulated tow bar

### Performance

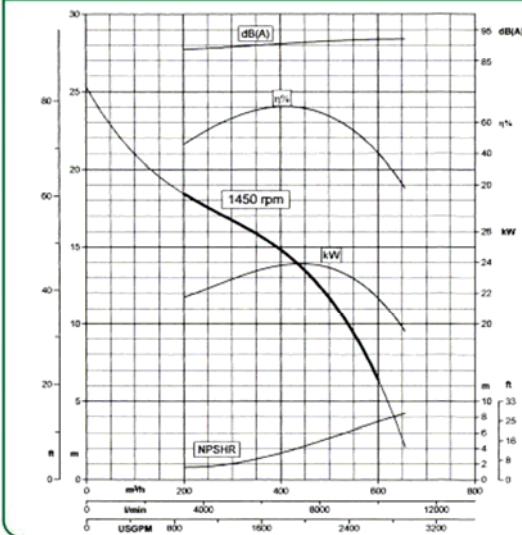

### Specifications

- Max. water capacity: 700 m<sup>3</sup>/h
- Max. head.: 23 m
- Speed: 1450 RPM
- Size of solids handled: 76 mm (2 blade impeller)
- Cast iron construction
- Rubber faced wear plate
- Silicon carbide mechanical seal with automatic lubricator
- Rated vacuum pump capacity: 75 m<sup>3</sup>/h
- Pump electric motor: 30 kW
- Control panel to CE standards

### Overall dimensions - Weight

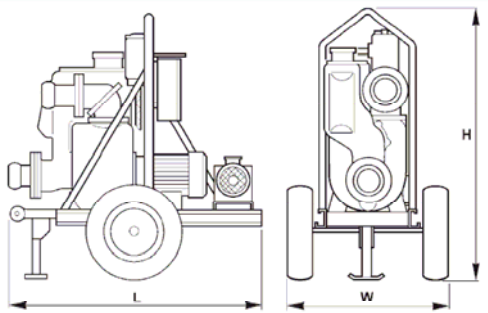

L	W	H	Weight
2100mm	1500mm	2100mm	1400kg

### Applications

- Wellpoint dewatering systems
- Horizontal drainage with drainage hoses
- Construction site dewatering
- Sewage by-pass
- Quarries
- Sludge and slurry

Code:

List price:



**VARISCO S.p.A.**  
 Zona Industriale Nord - 35129 PADOVA - ITALIA  
 Direzione e Uffici: Terza Strada, 9 / Produzione e magazzini: Prima Strada, 37  
 Tel. +39 049 8294111 - international +39 049 8294111  
 Fax +39 049 8294373 +39 049 8076762  
 italia@variscospa.com export@variscospa.com  
 www.variscospa.com

AZIENDA CON SISTEMA  
 GESTIONE QUALITA'  
 CERTIFICATO  
 UNI EN ISO 9001-2000