



Intake/delivery connections 2" - flow rate 650 l/min

# BOXER 502



STANDARD: II 3/3G D IIB T 135°C (zone 2)  
CONDUCT: II 2/2GD c IIB T 135°C (zone 1)

Intake/delivery connections G 2" f (standard)  
with flange DN 50 (on request)

Air connection G 1/2" f

Max. self-priming capacity\* 4 m

Max. flow rate\* 650 l/min

Max. head\* 70 m

Max. air supply pressure 7 bar

Max. diameter of passing solids (spherical particles) 8 mm

Construction materials	Weight	Max. operating temp.
PP	48 Kg	60°C
PVDF	65 Kg	95°C



PP

## TECHNICAL DATA



PVDF

■ Air supply pressure  
■ Air consumption NI/min

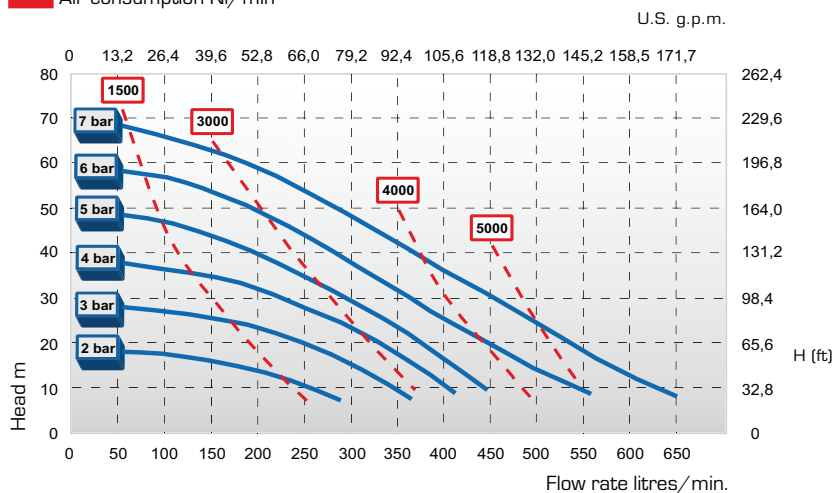

PERFORMANCE

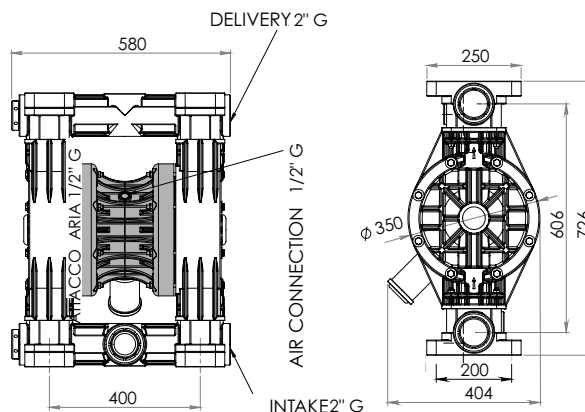

The dimensions shown are in mm

DIMENSIONS

\*The curves and performance values refer to pumps with submerged suction and a free delivery outlet with water at 20°C, and vary according to the construction material. All the values shown are approximate and not binding

Intake/delivery connections 2" - flow rate 650 l/min

# BOXER 502



STANDARD: II 3/3G D IIB T 135°C (zone 2)  
 CONDUCT: II 2/2GD c IIB T 135°C (zone 1)



ALU

Intake/delivery connections	G 2" f (standard) with flange DN 50 (on request)	
Air connection	G 1/2" f	
Max. self-priming capacity*	4 m	
Max. flow rate*	650 l/min	
Max. head*	70 m	
Max. air supply pressure	7 bar	
Max. diameter of passing solids (spherical particles)	8 mm	

Construction materials	Weight	Max. operating temp.
Aisi 316	54 Kg	95°C
Alu	49 Kg	95°C

## TECHNICAL DATA

## PERFORMANCE

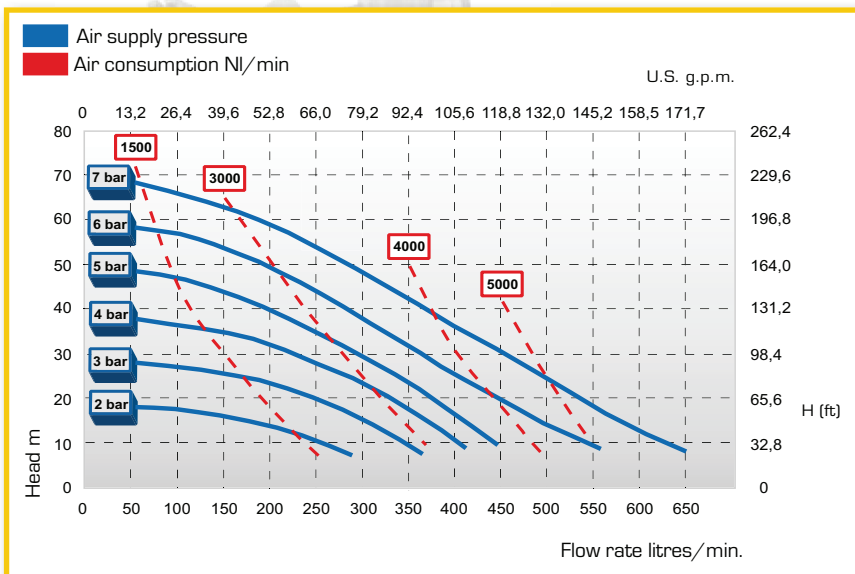

Aisi 316

## DIMENSIONS

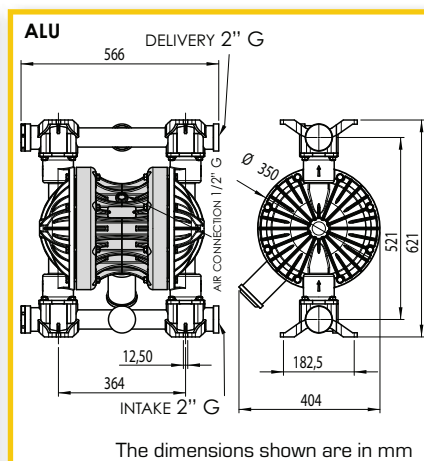
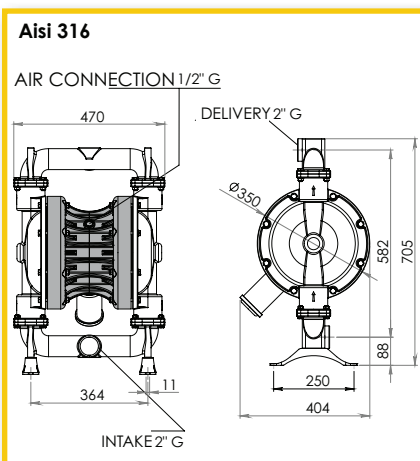

The dimensions shown are in mm

\*The curves and performance values refer to pumps with submerged suction and a free delivery outlet with water at 20°C, and vary according to the construction material.  
 All the values shown are approximate and not binding